

P/N	FIG.	A (OPEN)	A (CLOSED)	B	O-RING	SPRING PRE-LOAD	SPRING RATE
-1CC		----- O B S O L E T E -----					
-2CC	1	.510	.460	.115±.001	NOT REQ'D	1.95 lbs	15.0 lbs/in
-3CC	2	.745	.695	.135±.001	NOT REQ'D	1.21 lbs	5.5 lbs/in
-4CC	2	.660	.610	.135±.001	REQ'D	1.21 lbs	5.5 lbs/in
-5CC	2	1.000	.950	.135±.001	REQ'D	1.21 lbs	5.5 lbs/in
-6CC	3	1.376	1.326	.115±.001	NOT REQ'D	2.80 lbs	11 lbs/in
-7CC		----- O B S O L E T E -----					

REVISIONS			
REV	DESCRIPTION	DATE	BY
L	ECO 31836 Add IL for -6CC	01.26.17	WM
M	ECO 201966	10.01.24	P.MAO
N	ECO 202352 (ADD NEW NAME)	12.02.24	DKN

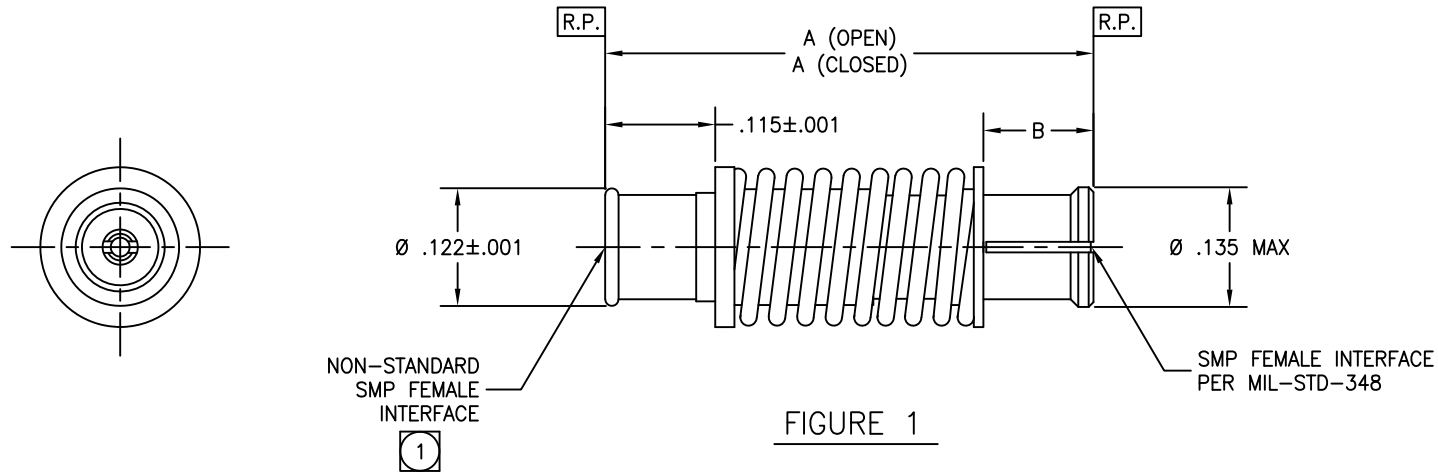

1. Non slotted SMP Female for use with smooth bore (Standard & Catcher's Mitt variants) SMP Male connector only.

MATERIAL(S):	ELECTRICAL:	MECHANICAL:	ENVIRONMENTAL:
Insert: 303 SST per ASTM A-582. Body & Center Conductor: BeCu alloy per ASTM B-196. Insulator: PTFE Teflon per ASTM D-1710. Spring: Stainless Steel O-Ring (See tabulation table): Silicone carbon filled elastomer, conductive, color black.	Impedance: 50 Ohms Nom. Frequency Range: DC to 18.0 GHz. VSWR: 1.35 max to 18.0 GHz. Insertion Loss: .10 √f (GHz) max. For -6CC: .60 from DC to 12.0 GHz. 1.20 from 12.0-18.0 GHz. Working Voltage: 335 Vrms @ Sea Level. Dielectric Withstand Voltage: 500 V rms. RF HiPot Voltage: 325 Vrms Min @ 5MHz. Corona Level: 190 Vrms @ 70,000 ft. Insulation Resistance: 5,000 Mohms. Contact Resistance: Center Contact: 6.0 Milliohm max. Outer Contact: 2.0 Milliohm max. R.F. Leakage: -80 dB DC to 3.0 GHz. -65 dB 3.0 GHz to 18.0 GHz.	Mating Characteristics: Interface per Mil-Std-348. Force To Engage: Full Detent: 15 lbs max. Limited Detent: 10 lbs max. Smooth Bore: 2 lbs max. Force To Disengage: Full Detent: 5 lbs min. Limited Detent: 2 lbs min. Smooth Bore: .5 lbs min. Center Contact Retention: Axial Force: 2 pounds min. Connector Durability: 100 cycles min @ 12 cycles/minute max. Permeability: Less than 2.0 mu.	Temp. Range: -65°C to +165°C Thermal Shock: MIL-STD-202, Method 107, Test Cond. B. Moisture Resistance: MIL-STD-202, Method 106. Insulation resistance at least 200 MegaOhms within 5 minutes after removal from humidity. Corrosion: MIL-STD-202, Method 101, Test Cond. B. Vibration: MIL-STD-202, Method 204, Test Cond. D. Shock: Mil-Std-202, Method 213, Test Cond. I.

FINISH(ES):
Body & Center Conductor: Gold plate per ASTM B-488 type II, code C, class 1.25 over nickel underplate per SAE AMS-QQ-N-290, class I Spring: Passivated per ASTM A-967 OR AMS-QQ-P-35 Insert: Gold plate per ASTM B-488 type II, code C, class 0.25 over nickel plate per SAE AMS-QQ-N-290, class I

APPLICABLE Amphenol CDI DOCUMENTS		
WORK STD	PROD INST	ASSY INST
NA	NA	NA

NOTICE

THIS DRAWING EMBODIES A CONFIDENTIAL PROPRIETARY DESIGN ORIGINATED BY Amphenol CDI AND ALL DESIGN, MANUFACTURING, RE-PRODUCTION, USE AND SALE RIGHTS REGARDING THE SAME ARE EXPRESSLY RESERVED. IT IS SUBMITTED UNDER A CONFIDENTIAL RELATIONSHIP FOR A SPECIFIED PURPOSE AND THE RECIPIENT AGREES BY ACCEPTING THIS DRAWING NOT TO SUPPLY OR DISCLOSE ANY INFORMATION REGARDING IT TO ANY UNAUTHORIZED PERSON TO INCORPORATE INTO OTHER PRODUCTS ANY SPECIAL FEATURE REGULAR TO THIS DESIGN. ALL PATENT RIGHTS HERETO ARE EXPRESSLY RESERVED BY Amphenol CDI, Cerritos, CA 90703

TOLERANCES AND NOTES EXCEPT AS NOTED	
INTERPRET DRAWING PER ASME Y14.5-2018	
DIMENSIONS ARE IN INCHES:	
LINEAR .001 ±.015	ANGULAR ± 1/2°
FRAC. ± 1/32	
1. MACHINE FINISH: 63/RMS 2. BREAK ALL SHARP EDGES .003 MAX. 3. MACHINED FILLETS .005 MAX. 4. MACHINED SURFACES SQUARE TO RESPECTIVE AXIS WITHIN .005 INCHES PER INCH. 5. MACHINED DIAMETERS CONCENTRIC WITHIN .002 T.I.R. 6. DIMENSIONS TO BE MET BEFORE PLATING. 7. CHAMFER ALL THREADS 45°. 8. THREADS PER H-28. 9. REMOVE FRAYED EDGES ON TEFLON. 10. REMOVE ALL BURRS.	

MATERIAL		SPECIFICATION		PROCUREMENT	
APPROVAL INITIALS	DATE			12900 Alondra Blvd. Cerritos, CA 90703	
DRAWN BY	DATE				
CHECKED BY	DATE	TITLE SMP FEMALE TO NON-STANDARD SMP FEMALE, SPRING LOAD, ADAPTER			
TEST ENGG		SCALE 10:1 DIRECTORY/SUB-DIRECTORY			
DESIGN ENGG	DATE	OUTLINE/ SHEET 1 of 2			
MFG ENGG		SIZE C 30990			
ECO APPRV	DATE	P922			
		REV. N			

4

3

2

1

D

D

C

C

B

B

A

A

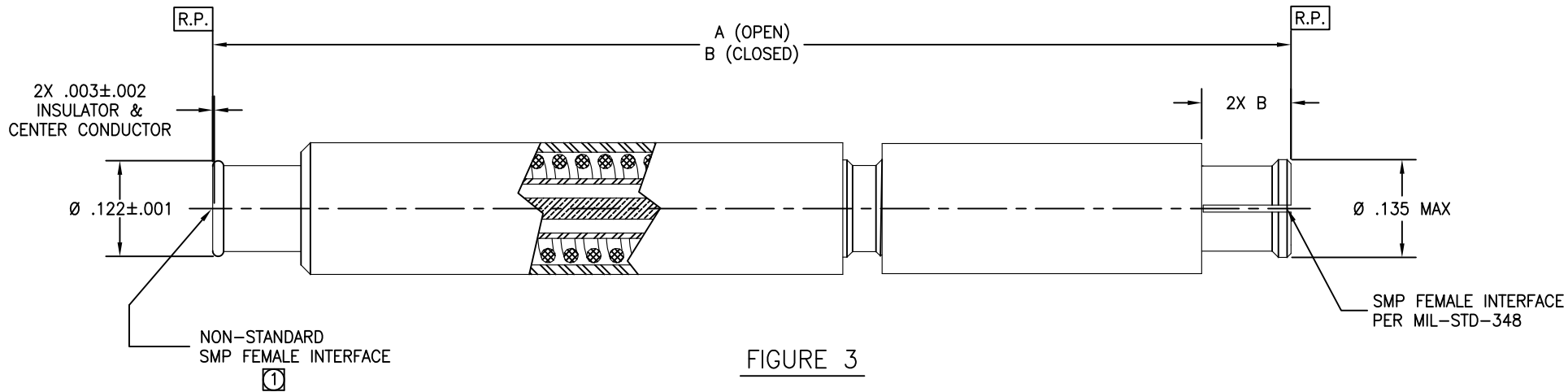

FIGURE 3

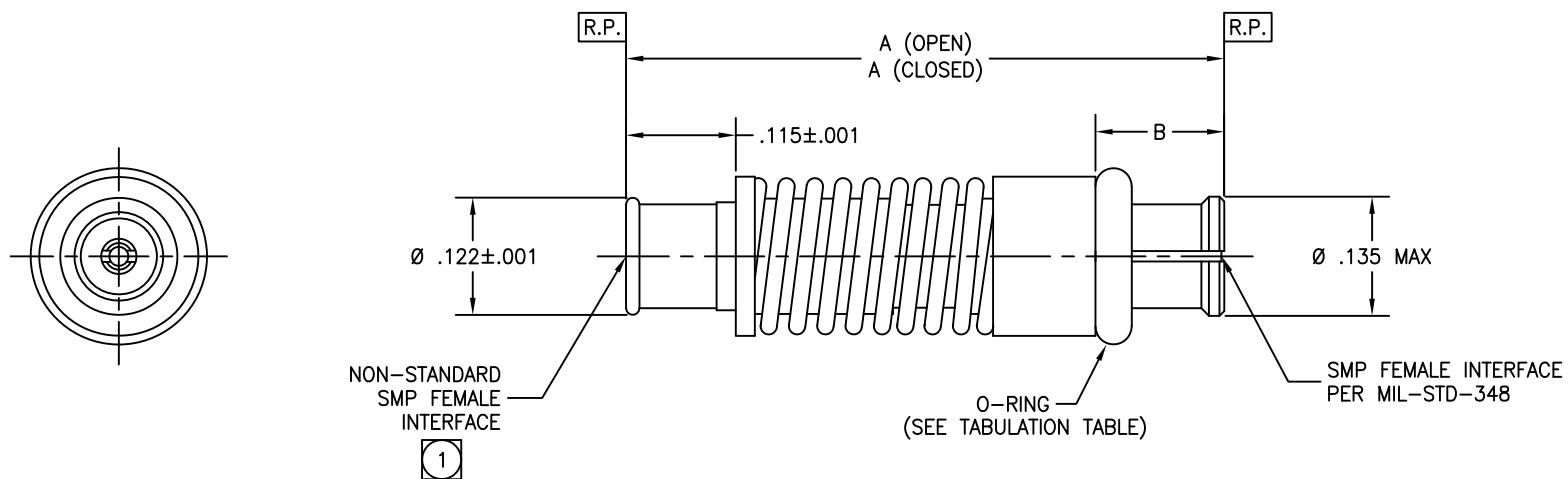

FIGURE 2

SCALE	10:1	DIRECTORY/SUB-DIRECTORY	OUTLINE/	SHEET	2	OF	2
SIZE	C	CAGE CODE	30990	DRAWING NO.	P922	REV.	N

4

3

2

1