

PART NO.	CAPTIVATION METHOD
BASIC	NONE
CC	EPOXY ONLY
SF	NONE
CCSF	EPOXY ONLY
CCCE	EPOXY WITH CONDUCTIVE
CCCESF	EPOXY WITH CONDUCTIVE
NP	NONE
CCNP	EPOXY ONLY

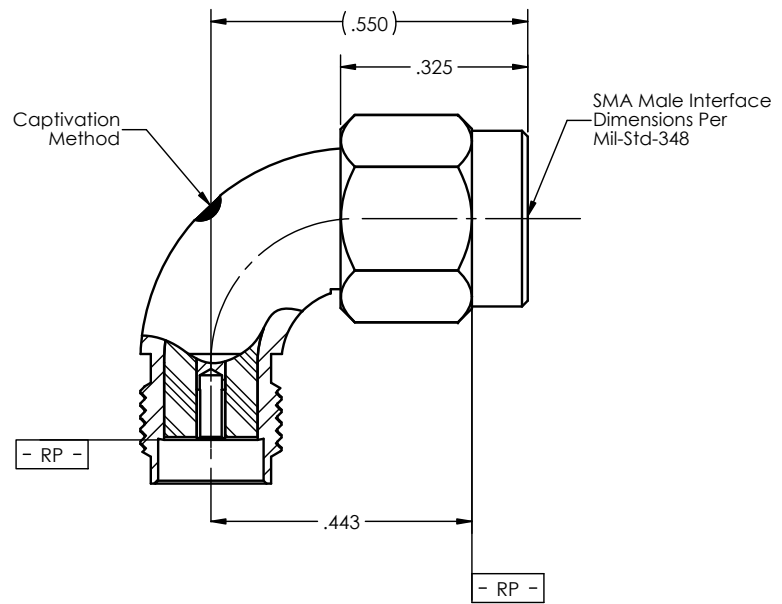

REVISIONS			
REV.	DESCRIPTION	DATE	BY
C	ECO 23119	5/5/2010	YP
D	ECO 28120(ADD NP,CCNP, REDRAW SW)	9/23/2014	YP
E	ECO 202352 (ADD NEW NAME)	11/21/2024	DKN

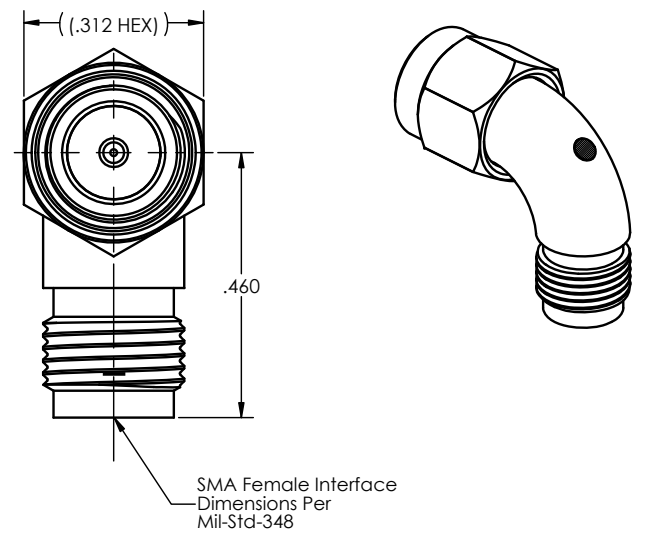

**MATERIAL(S):**  
 Body:  
 304 SST per AMS 5567.  
 Coupling Nut:  
 303 SST per ASTM A-582.  
 Center Conductor:  
 BeCu Alloy per ASTM B-196.  
 Retaining Ring:  
 BeCu Alloy per ASTM B-197.  
 Dielectric:  
 PTFE Teflon per ASTM D-1710  
 Gasket:  
 Silicone rubber per A-A-59588.  
 Epoxy:  
 Sigma vary flex type HV  
 Conductive Epoxy:  
 Eccobond 56C.

**ELECTRICAL(S):**  
 Impedance: 50 Ohms Nominal.  
 Frequency Range: DC to 18.0 GHz.  
 VSWR: 1.15 + .006 x f (GHz) for BASIC, SF, & NP.  
 1.25:1 max for CC, CCSF, CCCE, CCCESF & CCNP  
 Insertion Loss: .20 dB max @ 18 GHz.  
 Working Voltage: 335 Vrms max @ Sea Level.  
 Dielectric Withstand Voltage: 1,500 Vrms min.  
 R.F. HiPot Voltage: 1,000 Vrms min. @ 5MHz.  
 Corona Level: 375 Vrms @ 70,000 ft.  
 Insulation Resistance: 5000 MegOhms min.  
 RF Leakage:  
 -(90-fGHz) dB min. for BASIC, SF & NP.  
 -(60-fGHz) dB min. for CC, CCCE & CCNP.  
 Contact Resistance:  
 Initial:  
 Center Contact: 3.0 Milliohms max.  
 Outer Contact: 2.0 Milliohms max.  
 After Environment:  
 Center Contact: 4.0 Milliohms max.  
 Outer Contact: NA.

**MECHANICAL(S):**  
 Mating Characteristics:  
 Interface per MIL-STD-348.  
 Force to Engage & Disengage:  
 Torque: 2 inch-pounds max.  
 Longitudinal Force: NA.  
 Connector Durability:  
 500 Cycles min. @ 12 cycles/minute max.  
 Permeability: Less than 2.0 mu.  
 Coupling Proof Torque: 15 inch-pounds min. \*  
 \* For Inspection Conditions: The mated pairs shall be torqued to 7 - 10 inch-pounds.  
 Coupling Mech. Retention: 60 pounds min.  
 Center Contact Retention (Captivation Only):  
 Axial Force: 6 pounds min.  
 Radial Torque: NA.

**ENVIRONMENTAL(S):**  
 Temp. Range: -65°C to +125°C (All Captivated)  
 -65°C to +1650°C (Basic & SF)  
 Thermal Shock:  
 MIL-STD-202, Method 107, Test Condition C.  
 Moisture Resistance:  
 MIL-STD-202, Method 106, except step 7b shall be omitted. Insulation resistance at least 1,000 MegaOhms within 5 minutes after removal from humidity.  
 Corrosion:  
 MIL-STD-202, Method 101, Test Condition B.  
 Vibration:  
 MIL-STD-202, Method 204, Test Condition D.  
 Shock:  
 MIL-STD-202, Method 213, Test Condition I.

**FINISH(ES):**  
 Body & Coupling Nut:  
 ( For SF, CCSF, CCESF ): Passivate per ASTM A-967 or SAE-AMS 2700.  
 ( For BASIC, CC, CCCE ): Gold plate per ASTM B-488, type II, Code C, Class 0.25 over nickel under plate per SAE-AMS-QQ-N-290, Class 1.  
 ( For NP, CCNP ): Nickel plate per SAE-AMS-QQ-N-290, Class 1, .000200 min. thick.  
 Center Conductor: Gold plate per ASTM B-488, type II, Code C or D, Class 1.25 over nickel under plate per SAE-AMS-QQ-N-290, Class 1.

APPLICABLE Amphenol CDI DOCUMENTS		
WORK STANDARD	PROD INSTRUC	ASSY INSTRUC
NA	NA	NA

**NOTICE**  
 THIS DRAWING EMBODIES A CONFIDENTIAL PROPRIETARY DESIGN ORIGINATED BY Amphenol CDI & ALL DESIGNS, MANUFACTURING, REPRODUCTION, USE & SALE RIGHTS REGARDING THE SAME ARE EXPRESSLY RESERVED. IT IS SUBMITTED UNDER A CONFIDENTIAL RELATIONSHIP FOR A SPECIFIED PURPOSE & THE RECIPIENT AGREES BY ACCEPTING THIS DRAWING NOT TO SUPPLY OR DISCLOSE ANY INFORMATION REGARDING IT TO ANY UNAUTHORIZED PERSON TO INCORPORATE IN OTHER PROJECTS AND SPECIAL FEATURES PECULIAR TO THIS DESIGN. ALL PATENT RIGHTS HERETO ARE EXPRESSLY RESERVED BY Amphenol CDI, CERRITOS, CALIFORNIA 94009.

- TOLERANCES AND NOTES**  
 EXCEPT AS NOTED  
 DIMENSIONS ARE IN INCHES.  
 XX ± .015  
 LINEAR XXX ± .005 ANGLUAR ± 1/2°  
 FRACTION ± 1/32  
 INTERPRET DRAWING PER ASME Y14.5 - 2018
1. MACHINE FINISH:  $\sqrt{}$  RMS
  2. BREAK ALL SHARP EDGES .003 MAX.
  3. MACHINED FILLETS .005 MAX.
  4. MACHINED SURFACES SQUARE TO RESPECTIVE AXES WITHIN .005 INCHES PER INCH.
  5. MACHINED DIAMETERS CONCENTRIC WITHIN .002 TLR.
  6. DIMENSIONS TO BE MET BEFORE PLATING.
  7. CHAMFER ALL THREADS 45°.
  8. THREADS PER H-28
  9. REMOVE FRAZY EDGES ON TEFLON.
  10. REMOVE ALL BURRS.

APPROVAL INITIALS	DATE
DRAWN BY AGS	02.12.02
CHECKED BY P.MAO	09.25.14
TEST ENGR	-
QUALITY	-
DESIGN ENG HN	06.21.10
MFG ENGR	-
ECO APPRV DNg	11.21.24

MATERIAL	SPECIFICATION	PROCUREMENT
12900 Alondra Blvd. Cerritos, CA 90703		
<b>TITLE</b> SMA MALE TO SMA FEMALE RADIUS RIGHT ANGLE, ADAPTER		
SCALE	SUB-DIRECTORY/	SHEET 1 OF 1
6:1	OUTLINE/	
SIZE C	DRAWING NO. 5490	REV. E