

FREQUENCY	RETURN LOSS/ (VSWR)	INSERTION LOSS (dB Max)
		∅. 079 CABLE
DC TO 14 GHz	-18 dB (1.29 : 1)	-1.41
14 TO 28 GHz	-14 dB (1.50 : 1)	-2.02
28 TO 40 GHz	-11 dB (1.78 : 1)	-2.61

REVISION HISTORY				
ECO	REV.	DESCRIPTION	DRAWN BY	DATE
206106	A	INITIAL RELEASE	HTRAN	06.11.26

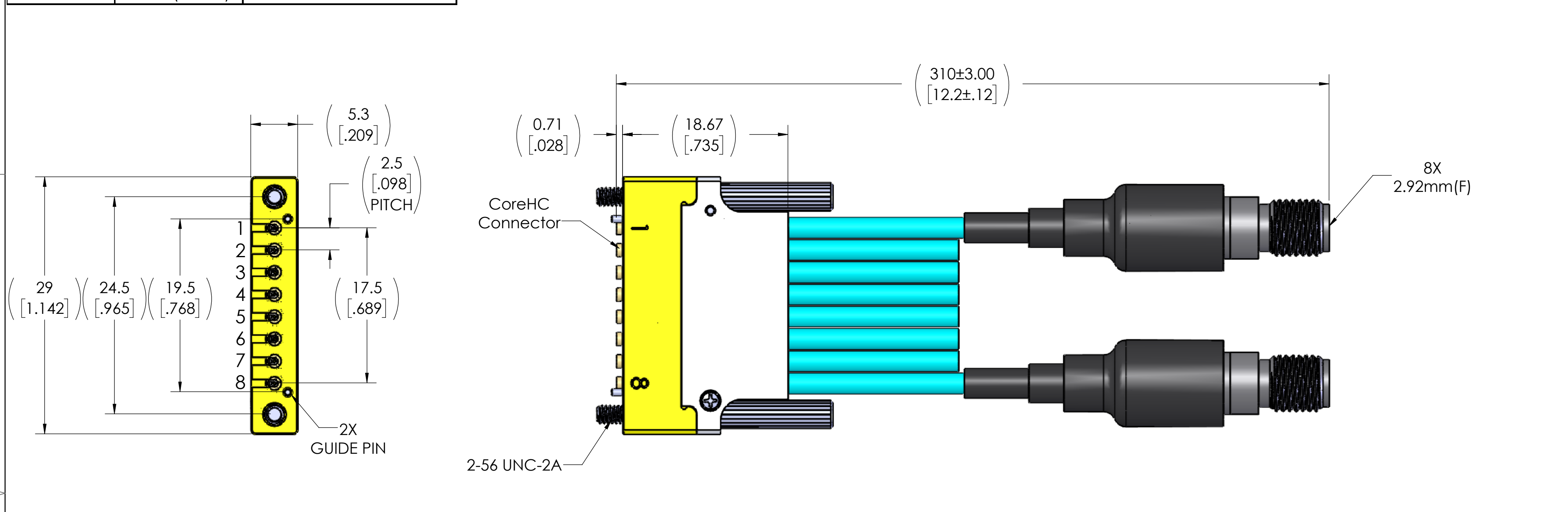

MATERIAL(S) & FINISH(ES):

CoreHC2 connector:
 Front Shell & Rear Shell:
 BeCu Alloy, Gold/Nickel Plating
 Ground Slider :
 Brass, Gold/Nickel Plating
 Spring:
 Music Wire, Nickel Plating
 Insulators:
 PTFE, Rexolite 1422 (unfilled)
 Spring pin:
 Barrel: Phosphor Bronze, Gold/Nickel Plating
 Plunger: BeCu Alloy/Brass, Gold/Nickel Plating
 Spring: Stainless Steel, No Plating
Precision connector:
 (Refer to Specification ACDI P/n TM7S-9FS-00)
HC2 Compliant Carrier:
 Carrier: Brass, Gold Plating
 Clamp Shell: Aluminum 6061, Anodize (Clear)
 Dowel Pin, Screw: Stainless Steel, Passivated
 Press Nut: Brass, Nickel Plating
Cable:
 Cable: P/n TM20-7S

ELECTRICAL(S):

Impedance: 50 Ohms Nominal
 Frequency Range: DC to 40 GHz
 VSWR: See Table
 Insertion Loss: See Table
 Working Voltage: 170 Vrms max @ Sea Level
 DWV: 325 Vrms max @ Sea Level
 Insulation Resistance: 5000 MegOhms min
 Spring Pin:
 Current: 1A Max.
 Contact Resistance: 100mOhm Max.
Phase Matched: +/-2pS (PAIR)

MECHANICAL(S):

Mating Characteristics:
 SMA Interface per MIL-STD 348
 CoreHC2 Interface per Amphenol CDI
 Force to Engage:
 CoreHC2 (Individual): .85 Lbs Typ.
 SMA: 2in-lbs max
 Force to Disengage:
 CoreHC2 (Individual): .N/A
 SMA: 2in-lbs max
 Connector Durability:
 CoreHC2: 1,000 Cycles
 SMA: 500 Cycles
 Permeability: Less than 2.0 mu.

ENVIROMENTAL(S):

Temperature Range: -65°C to +125°C
 Thermal Shock:
 MIL-STD-202, Method 107, Test Condition B
 Moisture Resistance:
 MIL-STD-202, Method 106, Insulation resistance at least 200 MegaOhms within 5 minutes after removal from humidity.
 Corrosion:
 MIL-STD-202, Method 101, Test Condition B
 Vibration:
 MIL-STD-202, Method 204, Test Condition D
 Shock:
 MIL-STD-202, Method 213, Test Condition I

THE INFORMATION CONTAINED HEREIN IS PROPRIETARY TO AMPHENOL AND SHALL IN NO WAY BE REPRODUCED OR DISCLOSED IN WHOLE OR IN PART OR USED FOR ANY DESIGN OR MANUFACTURE EXCEPT WHEN SUCH USER POSSESSES DIRECT, WRITTEN AUTHORIZATION FROM AMPHENOL.

DIMENSIONS ARE IN MILLIMETERS [INCHES] ± TOLERANCES UNLESS OTHERWISE NOTED		MATERIAL		SPECIFICATION		PROCUREMENT			
X ± 0.3mm [.012"] XX ± 0.15mm [.006"] .XXX ± 0.050mm [.002"] .XXXX ± 0.010mm [.0004"] ANGLE ± 0.5°		APPROVAL	INITIALS	DATE	Amphenol 12900 Alondra Blvd. Cerritos, CA 90703		TITLE CoreHC 079 Ass'y, 1xRow HC2 8CH to 2.92mm(F)		
DRAWN BY		HT	06.11.26	SCALE					SHEET 1 OF 1
NEXT ASSY.		USED ON		SEE ECO FOR APPROVAL SIGNATURES		SIZE	CAGE CODE	DRAWING NO.	REV.
APPLICATION		THIRD ANGLE PROJECTION		C		30990	TM7SSSH28R9FS031C	A	

